

AccuPro2000 / SR-2000

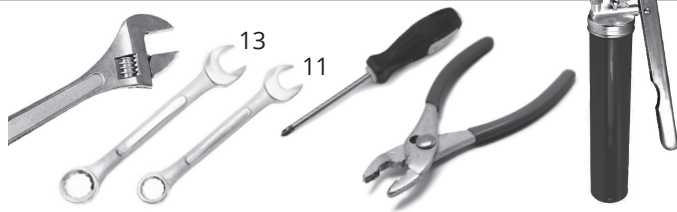

ENG	Assembly, use and care
ES	Montaje, uso y mantenimiento
FR	Montage, utilisation et entretien
DE	Gebrauchs- und Montageanweisung
IT	Assemblaggio, utilizzo e manutenzione
PL	Montaż, użytkowanie i konserwacja
NL	Montage, gebruik en onderhoud

Needs
Herramientas
Outils nécessaires
Benötigte Werkzeuge
Cosa serve
Potrzebne narzędzia
Benodigd gereedschap



Read instructions thoroughly and verify all parts are included. / Leer las instrucciones atentamente y verificar todas las piezas incluidas. / Lire attentivement les instructions et vérifier qu'il ne manque aucune pièce. / Lesen Sie die Gebrauchsanweisung vor der Nutzung und stellen Sie sicher, dass alle Teile enthalten sind. / Leggere attentamente le istruzioni e verificare che tutti i pezzi siano inclusi. / Prosimy zapoznać się z załączoną instrukcją i sprawdzenie zawartości opakowania. / Lees de instructies aandachtig en controleer of alle onderdelen aanwezig zijn.

Assembly / Montaje / Montage / Montage / Assemblaggio / Montaž / Montage

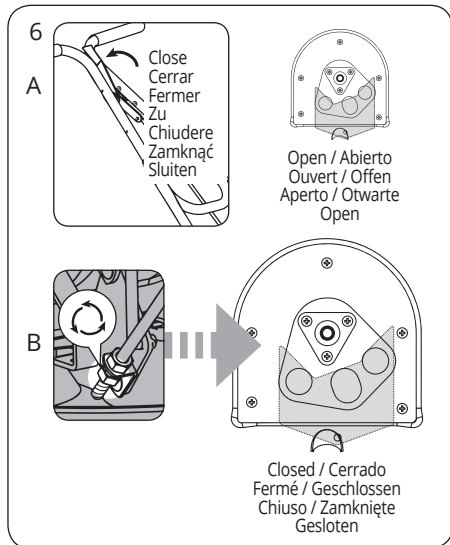
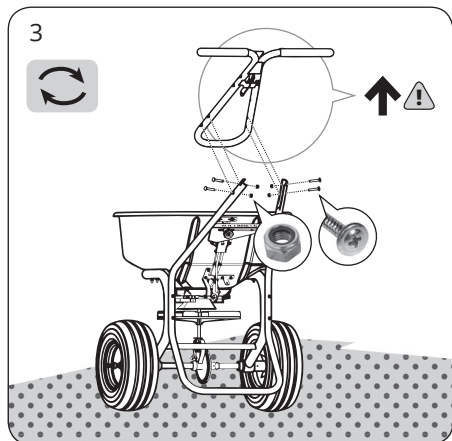
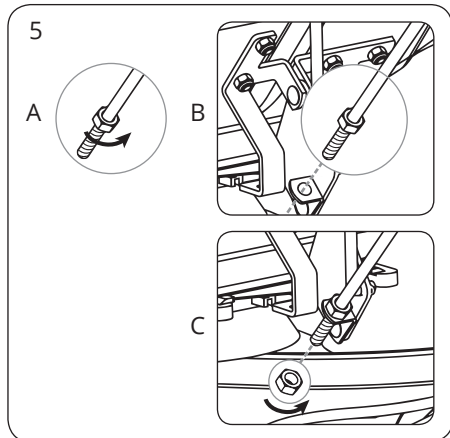
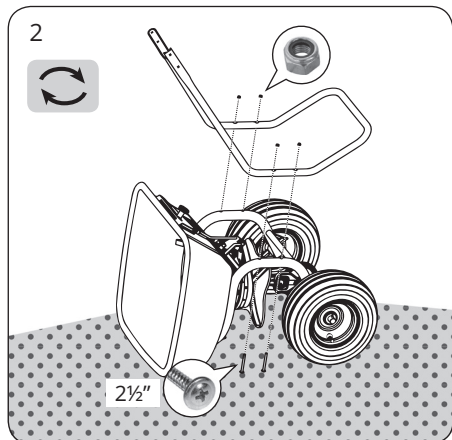
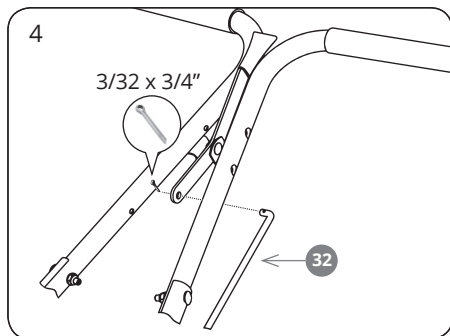
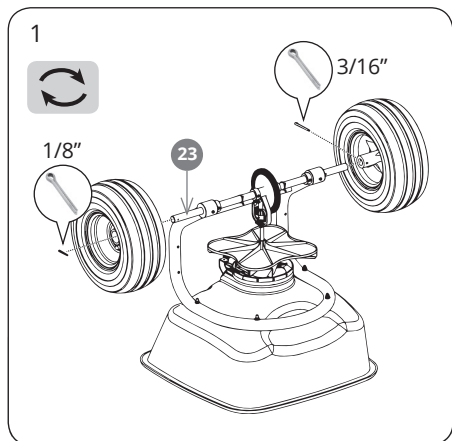



Accupro-2000

Assembly / Montaje / Montage

Montage / Assemblaggio

Montaż / Montage

#Nr. 36-44

- 200 Optional Deflector Kit
- 200 Kit del deflector opcional
- 200 Kit de déflecteur en option
- 200 Optional kpl. Ablenblech-Montagesatz
- 200 Kit opzionale paratia laterale
- 200 Boczny ogranicznik - opcjonalnie
- 200 Deflector kit (optioneel)

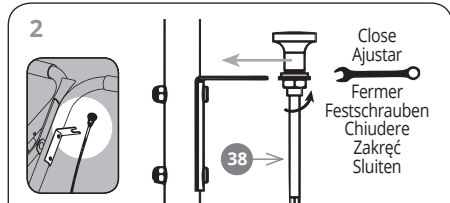
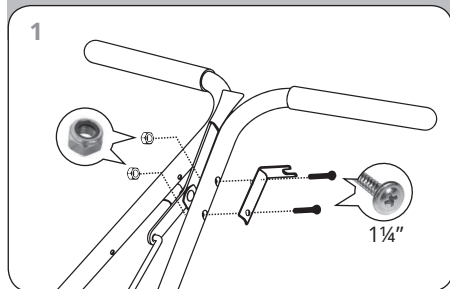

Close
Ajustar
Ferner
Festschrauben
Chiudere
Zakreć
Sluiten

Prevent twisting cable / Evitar la torsión del cable / Eviter de torsader le câble / Kabel nicht verdrehen / Evitare la torsione del cavo / Unikać skrećenia przewodu / Voorkom verdraaide kabels

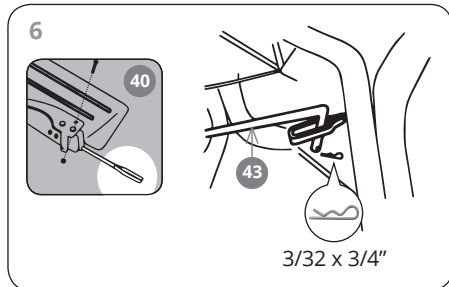
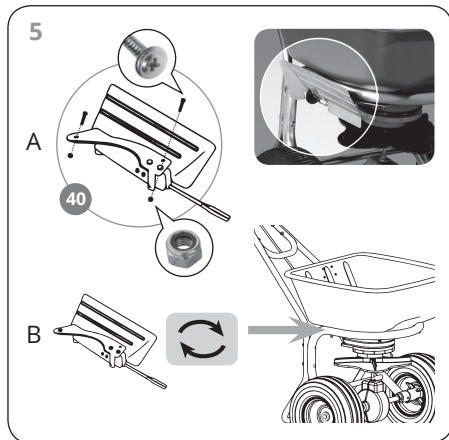
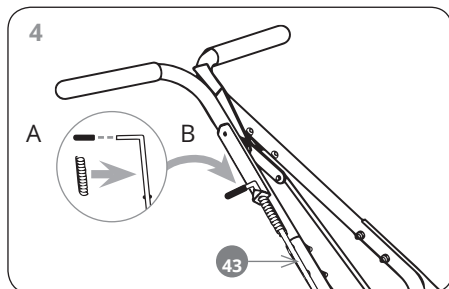
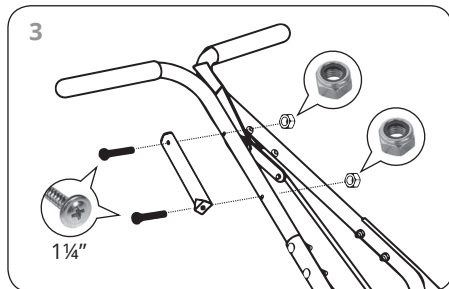

Assembly / Montaje / Montage / Montage / Assemblaggio / Montaż / Montage

7 On / Abierto / Marche / Auf / Aperto / Włączono / Aan

A B

Off / Cerrado / Arrêt / Zu / Chiuso / Wyłączone / Uit

A B

9

8

10

Operation / Modo de empleo / Utilisation / Bedienung / Utilizzo / Użytkowanie / Werking

1

Series	Application Method	Rate (kg/ha)	Row Spacing	Row Width	Seedbed Depth	Application Rate
1x	Hand	6	L½	5.0 mm	30 g/m ²	
2x	Hand	6	J½	5.0 mm	30 g/m ²	

2

Operation / Modo de empleo / Utilisation / Bedienung / Utilizzo / Użytkowanie / Werking

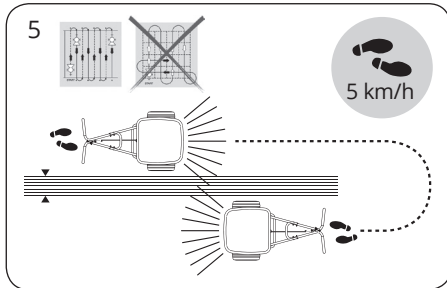
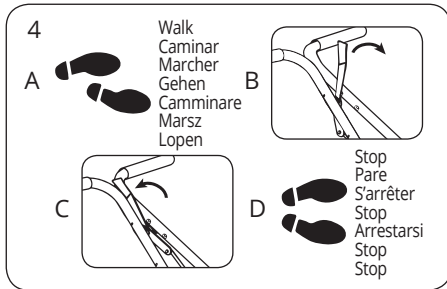
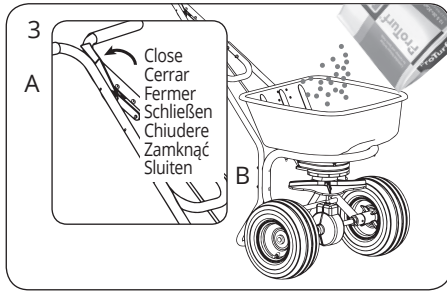

Operation / Modo de empleo / Utilisation / Bedienung / Utilizzo / Użytkowanie / Werking

ENG Use swath width recommended. Test rate and pattern on a small area. Results can depend on weather, spreader condition and walking speed.

ES Usar el ancho de abonado recomendado. Realice una prueba en una zona pequeña. Los resultados de la aplicación, pueden variar según el clima, el usuario y la velocidad al caminar.

FR Utiliser la largeur d'application recommandée. Vérifier le débit et l'homogénéité d'épandage sur une zone restreinte. Les résultats peuvent varier en fonction des conditions climatiques, de l'état de l'épandeur et de la vitesse à laquelle vous marchez.

DE Die auf der Verpackung für Ihren Streuertyp angegebene Streubreite verwenden. Streumenge und -muster sollten zunächst auf einer kleinen Fläche getestet werden. Die tatsächliche Streurrate kann je nach Wetter, Bedienung, Zustand des Streuers und Gehtempo unterschiedlich sein.

IT Usare la larghezza di spargimento raccomandata. Verificare la dose e la modalità di caduta in un'area circoscritta. I risultati possono dipendere dalle condizioni atmosferiche, dal carrello stesso e dalla velocità della camminata.

PL Ustaw zalecaną szerokość siewu. Zaleca się przetestowanie ustawień na niewielkiej powierzchni. Uzyskane wyniki mogą zależeć od warunków pogodowych, stanu technicznego siewnika, prędkości przemieszczania się podczas pracy.

NL Gebruik de aanbevolen breedtegang. Test de dosering en het strooi patroon op een kleine oppervlakte. De resultaten kunnen verschillen door weersomstandigheden, toestand van de strooier en loopsnelheid.

Operation & Maintenance / Modo de empleo & Mantenimiento / Utilisation & Maintenance / Bedienung & Wartung / Utilizzo & Manutenzione / Użytkowanie & Przygotowanie do pracy / Gebruik & Onderhoud

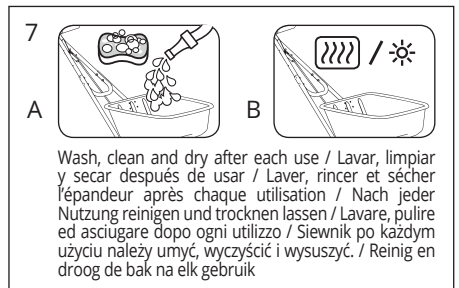
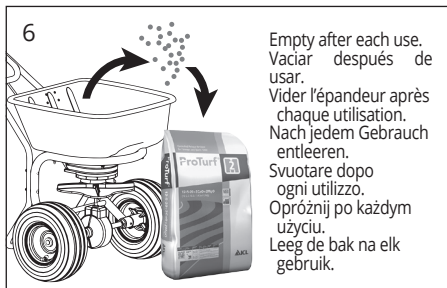

8

max. 20psi
max. 1,4 bar

9 Disassembly (Only if necessary) / Desmontaje (Solo si es necesario) / Démontage (Uniquement si nécessaire) / Demontage (Nur wenn notwendig) / Smontaggio (Solo se necessario) / Demontaż (tylko jeśli to konieczne) / Ontmanteling (Alleen indien nodig)

Driving wheel
Rueda motriz
Roue d'entraînement
Rad drehen
Ruota di trasmissione
Kolo Rijwiel

Rotorplate rotates clockwise / El plato rotativo gira a la derecha / La plaque de rotor pivote dans le sens des aiguilles d'une montre / Rotorplatte dreht sich im Uhrzeigersinn / Ruotare la placca di trasmissione in senso orario / Płyte wirnika obróć zgodnie ze wskazówkami zegara. / Roterende schijf draait rechtsom

Calibration / Calibración / Étalonnage / Kalibrierungsanweisung / Calibrazione / Kalibracja / Kalibreren

1

A

B

In 'E' position
En la posición 'E'
En position 'E'
in die 'E' Position bringen
In posizione 'E'
W pozycji 'E'
In de 'E' stand

2

45

Calibration depth
Profundidad de calibración
Profondeur d'étalonnage
Kalibrierungstiefe
Profondità di calibrazione
Kalibracja
Kalibreerdiepte

Calibrate only if necessary / Calibrar solo si es necesario / Procéder à l'étalonnage uniquement si cela s'avère nécessaire / Kalibrierung nur wenn notwendig / Calibrare solo se necessario / Kalibracja tylko gdy niezbędna / Kalibreren alleen indien nodig

Calibration / Calibración / Étalonnage / Kalibrierungsanweisung / Calibrazione / Kalibracja / Kalibreren

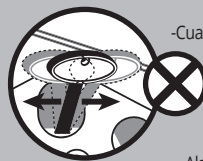

-When calibration key does not fit snugly
-Cuando la llave de calibración no encaja bien
-Lorsque la davette d'étalonnage ne s'insère pas correctement
-Wenn der Eichstift nicht eng anliegt
-Quando la chiave di calibrazione non si adatta agevolmente
-Gdy klucz do kalibracji jest luzny
-Als de kalibreersleutel niet gemakkelijk past



3

A

B

Open / Abrir
Ouvrir / Lösen / Aprire
Otwórz / Open

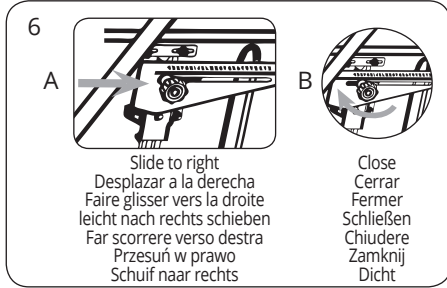
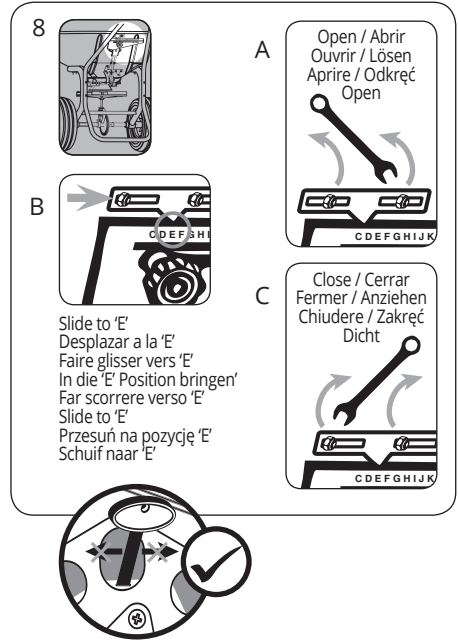
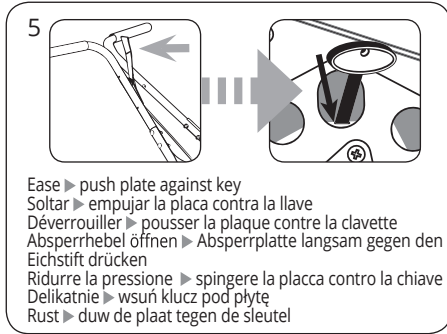
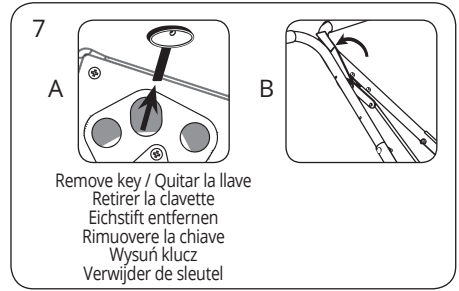
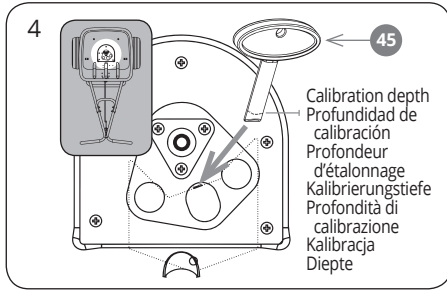

Parts Diagram / Despiece / Schéma de pièces / Einzelteilzeichnung / Pezzi di ricambio / Schemat budowy / Onderdelenschema

ACCUPRO-2000 #Nr. 36-44

200 Optional Deflector Kit / Kit del deflector opcional / Kit de déflecteur en option / Optional kpl. Ablenkblech-Montagesatz / Kit opzionale paratia laterale / Boczny ogranicznik - opcjonalnie / Deflector kit (optioneel)

Used for side spread pattern shut off / Este Kit permite no abonar por el lateral derecho / en cas d'utilisation d'un levier de fermeture pour épandage latéral / Zur Verwendung für den Randbegrenzer / Da utilizzare per escludere lo spargimento laterale / Do stosowania przy siewie wzdłuż krawędzi / Voor het afsluiten van een zijkant

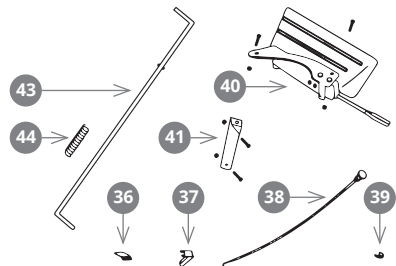

See Assembly P.3 / Ver montage P.3 / Consulter la section Montage à la P.3 / Siehe 'Montage' S.3 / Vedi 'Assemblaggio' P.3
See Assembly P.3 / Zie Montage P.3

Parts Diagram / Despiece / Schéma de pièces / Einzelteilzeichnung
 Pezzi di ricambio / Schemat budowy / Onderdelenschema

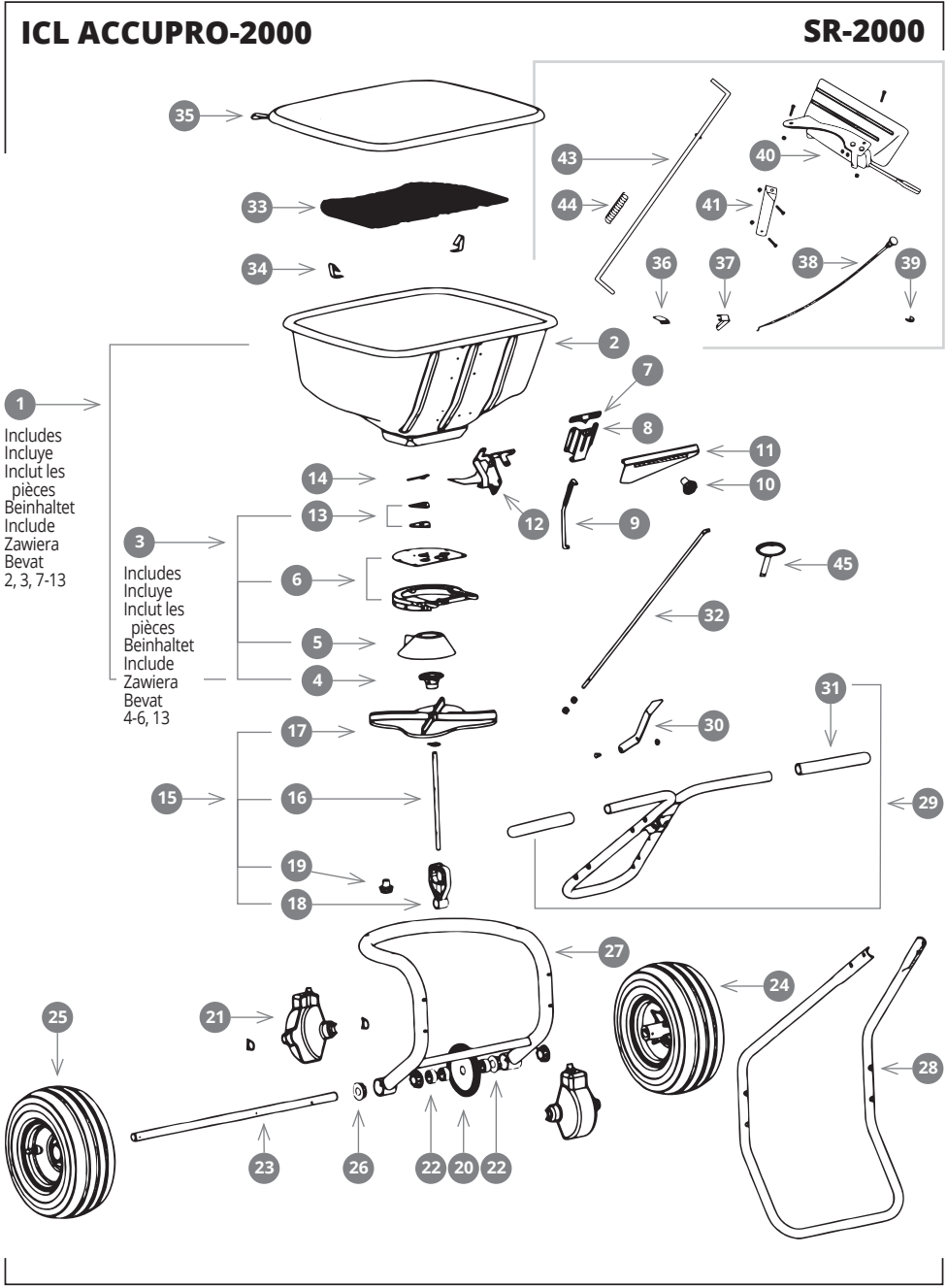

Ordering parts / Listado de piezas

#Nº.	Part description	ENG	Part nr.
1	Hopper Assembly Accupro-2000		16555
	Hopper Assembly SR-2000		16558
2	* Hopper		16554
3	* Helical Cone Assembly		780945
4	* Helical Cone Retainer		791025
	Bearing Shield		23456
5	Helical Cone		780941
6	* Shutoff Plate Retainer		780235
	Shutoff Plate Base		791070
7	* Pointer		790342
8	* Rate Housing Assembly and take off		790321
9	* Rate Control Rod Assembly		790321
	Spring		15460
	Rate Housing		790320-04PS
	Rate control rod		790390
10	* Rate Control Knob		12704
	Friction washer		12140
11	* Rate Control Plate Accupro-2000		790331
	* Rate Control Plate SR-2000		790331-A
12	* Pivot Lever / Main Shutoff Plate Assembly		790266
13	* Agitator Bearing, Set		792004
14	Agitator Pin		780100
15	Rotor and Gear Carrier Assembly		780195
16	Rotor Shaft		790020
17	Rotor Plate		780191
18	Gear Carrier, complete		780155
19	Pinion Gear		780122
20	Ring Gear		780121
21	Gearbox Cover Half (set of 2)		780110-B
22	Axle Collar (each)		14971-1
	Axle Collar (each)		780200

*Indicates parts included with hopper assembly

#Nº.	Part description	ENG	Part nr.
23	Axle, complete		790010
24	Drive Wheel		790120
25	Idler Wheel		790130
26	Axle Bearing (set of 4)		790151
27	Frame Assembly (includes 26) Accupro-2000		790045
	Frame Assembly (includes 26) SR-2000		790046
28	Rest Accupro-2000		790061
	Rest SR-2000		790060
29	Handle Assembly Accupro-2000		790075
	Handle Assembly SR-2000		790076
30	Main Shutoff Lever		790211-04
31	Hand Grips (set of 2)		14870
32	Main Shutoff Control Rod		790250
33	Hopper Screen		790141
34	Hopper Screen Clip (set of 2)		14864
35	Hopper Cover		1067
36	- Auxiliary Shutoff Plate		780220
37	- Auxiliary Shutoff Cable Bracket		790552
38	- Auxiliary Shutoff Control Cable		790490
39	- Auxiliary Shutoff Clamp		790560
40	- Deflector Shield (complete)		1000060
41	- Deflector Lever Bracket		1000059
43	- Deflector Control Rod		1000053
44	- Spring for Deflector Rod		1000052
45	Calibration Key (see calibration instructions)		15740
	Fastener Package (not shown)		790905
200	Parts 36-44: Complete Deflector Kit		1000060

All part and subassembly kits include necessary fasteners and assembly instructions

#Nº.	Descripción de las piezas	ES	Nº de pieza
1	Conjunto tolva Accupro-2000		16555
	Conjunto tolva SR-2000		16558
2	* Tolva		16554
3	* Conjunto montaje cono helicoidal		780945
4	* Retén cono helicoidal		791025
	Protector rodamiento		23456
5	Cono helicoidal		780941
6	* Paso de retención plato de cierre		780235
	Base plato de cierre		791070
7	* Puntero indicador		790342
8	* Rate Housing Assembly and take off		790321
9	* Montaje barra dosificador		790321
	Spring		15460
	Rate Housing		790320-04PS
	Rate control rod		790390
10	* Perno y arandela para dosificador		12704
	Friction washer		12140
11	* Placa base dosificador Accupro-2000		790331
	* Placa base dosificador SR-2000		790331-A
12	* Cjto montaje brazo oscilante/Cierre placa principal		790266
13	* Cjto. cojinetes del agitador		792004
14	Clavija agitador		780100
15	Cjto montaje rotor y engranaje del cargador		780195
16	Eje del rotor		790020
17	Placa del rotor		780191
18	Engranaje completo cargador		780155
19	Piñón del engranaje		780122
20	Anilla del engranaje		780121
21	Media cubierta caja engranajes (set de 2)		780110-B
22	Cuello del eje (cada uno)		14971-1
	Cuello del eje (cada uno)		780200

*Marca las piezas incluidas en el montaje de la tolva 'Hopper'

#Nº.	Descripción de las piezas	ES	Nº de pieza
23	Eje, completo		790010
24	Rueda de tracción		790120
25	Rueda con piñón loco		790130
26	Cojinete del eje (set de 4)		790151
27	Conjunto bastidor (incluye 26) Accupro-2000		790045
	Conjunto bastidor (incluye 26) SR-2000		790046
28	Resto del bastidor Accupro-2000		790061
	Resto del bastidor SR-2000		790060
29	Conjunto manillar Accupro-2000		790075
	Conjunto manillar SR-2000		790076
30	Palanca del cierre principal		790211-04
31	Mangos (set de 2)		14870
32	Barra del cierre principal		790250
33	Pantalla de la tolva		790141
34	Clips para pantalla de la tolva (set de 2)		14864
35	Cubierta de la tolva		1067
36	- Placa de cierre auxiliar		780220
37	- Soporte para el cable de cierre auxiliar		790552
38	- Cable de control del cierre auxiliar.		790490
39	- Clip del cierre auxiliar		790560
40	- Panel del deflector (completo)		1000060
41	- Soporte de la palanca del deflector		1000059
43	- Varilla de control del deflector.		1000053
44	- Muelle para la varilla del deflector		1000052
45	Flave de calibración		15740
	Paquete de tornillos (no mostrado)		790905
200	Piezas 36-44: Kit deflector completo		1000060

Todos los kits, sub-kits y conjuntos de piezas incluyen sus cierres necesarios e instrucciones de montaje

ENG See diagram for assistance in identifying specific parts.

 When ordering replacement parts, always provide the following information:
 - ALWAYS Use Part nr., never use #Nr.
 - Part Description

ES Consultar el despiece, para identificar la pieza de recambio.

 Cuando pida repuestos de piezas, siempre proporcionar la siguiente información:
 - SIEMPRE use el Nº de pieza, nunca use #Nr.
 - Descripción de las piezas

Commande de pièces / Ersatzteilliste

#Nr.	Description de la pièce	FR	Référence
1	Semoir et accessoires Accupro-2000		16555
	Semoir et accessoires SR-2000		16558
2	* Semoir		16554
3	* Ensemble cône hélicoïdal		780945
4	* Helical Cone Retainer		791025
	Bearing Shield		23456
5	Cône hélicoïdal		780941
6	* Shutoff Plate Retainer		780235
	Shutoff Plate Base		791070
7	* Indicateur		790342
8	* Rate Housing Assembly and take off		790321
9	* Ensemble tige de commande de débit		15460
	Spring		790320-04PS
	Rate Housing		790321
	Rate control rod		790390
10	* Molette de commande de débit		12704
	Friction washer		12140
11	* Plaque de commande de débit Accupro-2000		790331
	* Plaque de commande de débit SR-2000		790331-A
12	* Ensemble plaque de fermeture principale/ levier du pivot		790266
13	* Palier d'agitateur, ensemble		792004
14	Tige d'agitateur		780100
15	Ensemble porte-engrenage et rotor		780195
16	Arbre de rotor		790020
17	Plaque de rotor		780191
18	Porte-engrenage, complet		780155
19	Pignon d'engrenage		780122
20	Roue dentée		780121
21	Couvercle de boîte d'engrenage (2 pièces)		780110-B
22	Collet d'essieu (unité)		14971-1
	Collet d'essieu (unité)		780200

*Pièces incluses avec l'ensemble trémie

#Nr.	Description de la pièce	FR	Référence
23	Essieu, complet		790010
24	Roue motrice		790120
25	Pignon de renvoi		790130
26	Support d'essieu (4 pièces)		790151
27	Ensemble châssis (pièce 26 incluse Accupro-2000)		790045
	Ensemble châssis (pièce 26 incluse) SR-2000		790046
28	Support Accupro-2000		790061
	Support SR-2000		790060
29	Ensemble poignée Accupro-2000		790075
	Ensemble poignée SR-2000		790076
30	Levier de fermeture principale		790211-04
31	Poignées (2 pièces)		14870
32	Tige de commande de fermeture principale		790250
33	Grille de semoir		790141
34	Pince de la grille de semoir (2 pièces)		14864
35	Couvercle du semoir		1067
36	- Plaque de fermeture auxiliaire		780220
37	- Support de câble de fermeture auxiliaire		790552
38	- Câble de commande de fermeture auxiliaire		790490
39	- Pince de fermeture auxiliaire		790560
40	- Panneau de déflecteur (complet)		1000060
41	- Support de levier de déflecteur		1000059
43	- Tige de commande de déflecteur		1000053
44	- Ressort de tige de déflecteur		1000052
45	Clavette d'étalement		15740
	Kit de dispositif de fixation (non illustré)		790905
200	Pièces 36-44: kit de déflecteur complet		1000060

Les instructions et les dispositifs de fixation nécessaires sont inclus dans chaque kit de sous-ensemble et de pièces

#Nr.	Bezeichnung	DE	Artikelnr.
1	Trichtersatz Accupro-2000		16555
	Trichtersatz SR-2000		16558
2	* Trichter		16554
3	* Helical Cone Montageset		780945
4	* Helical Cone Retainer		791025
	Bearing Shield		23456
5	Helical Cone		780941
6	* Shutoff Plate Retainer		780235
	Shutoff Plate Base		791070
7	* Zeiger		790342
8	* Rate Housing Assembly and take off		790321
9	* Innenzylinder Streurenregelung		790321
	Spring		15460
	Rate Housing		790320-04PS
	Rate control rod		790390
10	* Streurenregler		12704
	Friction washer		12140
11	* Streurenregelplatte Accupro-2000		790331
	* Streurenregelplatte SR-2000		790331-A
12	* Lenkbügel		792006
13	* Satz Mischerlager		792004
14	Rührwerk		780100
15	Rotor-Getriebeträgersatz		780195
16	Rotorwelle		790020
17	Rotorplatte		780191
18	Getriebeträger komplett		780155
19	Ritzel		780122
20	Ringrad		780121
21	Getriebekastenhälfte (2x)		780110-B
22	Achsbund (je 1)		14971-1
	Achsbund (je 1)		780200

*Zeigt mit dem Fülltrichterzusammenbau eingeschlossene Teile an

#Nr.	Bezeichnung	DE	Artikelnr.
23	Achsstange		790010
24	Antriebsrad		790120
25	Lauftrad		790130
26	Achslager (4x)		790151
27	Rahmen (incl. 26) Accupro-2000		790045
	Rahmen (incl. 26) SR-2000		790046
28	Stützrahmen Accupro-2000		790061
	Stützrahmen SR-2000		790060
29	Griffsatz Accupro-2000		790075
	Griffsatz SR-2000		790076
30	Hauptabsperrehebel		790211-04
31	Handgriff (Set mit 2 Stk.)		14870
32	Hauptabsperrstreuerstab		790250
33	Trichtergitter		790141
34	Trichtergitterklammer (2x)		14864
35	Trichterdeckel		1067
36	- Absperrihlfplatte		780220
37	- Kabelhlfsträger (Abspermechan.)		790552
38	- Streuerhlfskabel (Abspermechan.)		790490
39	- Absperrihlfklemme		790560
40	- Ablenkblech komplett		1000060
41	- Deflektorstützhebel		1000059
43	- Steuerstab		1000053
44	- Feder		1000052
45	Eichschlüssel		15740
	Schraubenspaket (nicht aufgeführt)		790905
200	Materialliste 36-44: Kompletter Ablenkblech-Montagesatz		1000060

Sämtliche Ersatzteile werden mit Schraubenzubehör geschickt

FR

 Référez-vous au schéma pour identifier des pièces spécifiques.

Lorsque vous commandez des pièces de remplacement, fournissez toujours les informations suivantes:

- TOUJOURS la référence de la pièce, et non pas son #Nr.
- Description de la pièce

DE

 Verwenden Sie die Einzelteilzeichnung um die speziellen Ersatzteile sicher zu erkennen.

Wenn Sie Ersatzteile bestellen, stellen Sie immer die folgende Information zur Verfügung:

- Artikelnummer
- Bezeichnung laut Tabelle

Ordinare i pezzi / spis części zamiennych

#Nr.	Descrizione del pezzo	IT	Cod. del pezzo
1	Gruppo tramoggia Accupro-2000		16555
	Gruppo tramoggia SR-2000		16558
2	* Tramoggia		16554
3	* Gruppo cono elicoidale		780945
4	* Helical Cone Retainer		791025
	Bearing Shield		23456
5	Cono elicoidale		780941
6	* Fermo piatto di chiusura		780235
	Base fermo piatto		791070
7	* Indicatore		790342
8	* Rate Housing Assembly and take off		790321
9	* Gruppo barra controllo dosaggio		790321
	Spring		15460
	Rate Housing		790320-04PS
	Rate control Rod		790390
10	* Manopola del controllo dosaggio		12704
	Friction washer		12140
11	* Piastra controllo dosaggio Accupro-2000		790331
	* Piastra controllo dosaggio SR-2000		790331-A
12	* Leva di perno - Gruppo piastra apertura/chiusura		790266
13	* Set cuscinetto miscelatore		792004
14	Ago del miscelatore		780100
15	Gruppo del rotore ed ingranaggio di trasmissione		780195
16	Albero di trasmissione		790020
17	Placca di trasmissione		780191
18	Ingranaggio di trasmissione, (completo)		780155
19	Pignone		780122
20	Ghiera		780121
21	Coperchio scatola ingranaggi, metà (set di 2)		780110-B
22	Ingranaggio assale (cad)		14971-1
	Ingranaggio assale (cad)		780200

*Indica parti incluse nel gruppo tramoggia

#Nr.	Descrizione del pezzo	IT	Cod. del pezzo
23	Assale (completo)		790010
24	Ruota di trasmissione		790120
25	Ruota di rinvio		790130
26	Cuscinetto dell'assale (set di 4)		790151
27	Gruppo telaio (include 26) Accupro-2000		790045
	Gruppo telaio (include 26) SR-2000		790046
28	Base alloggio tramoggia Accupro-2000		790061
	Base alloggio tramoggia SR-2000		790060
29	Gruppo impugnatura Accupro-2000		790075
	Gruppo impugnatura SR-2000		790076
30	Leva principale apertura/chiusura		790211-04
31	Manopole (set di 2)		14870
32	Barra principale controllo apertura/chiusura		790250
33	Schermatura reticolare tramoggia		790141
34	Clip per schermatura tramoggia (set di 2)		14864
35	Copertura trasparente di protezione		1067
36	- Piastra di chiusura parziale		780220
37	- Supporto per cavo di chiusura parziale		790552
38	- Cavo di comando per chiusura parziale		790490
39	- Clip di chiusura parziale		790560
40	- Paratia laterale (completa)		1000060
41	- Supporto leva paratia laterale		1000059
43	- Barra di comando paratia laterale		1000053
44	- Molla della barra di comando paratia laterale		1000052
45	Chiave di settaggio		15740
	Pacchetto elementi di fissaggio (non illustrato)		790905
200	Pezzi 36-44: Kit completo paratia laterale		1000060

Tutti i pezzi ed i kits includono gli elementi di fissaggio necessari e le istruzioni di assemblaggio

#Nr.	Nazwa elementu	PL	Nr części
1	Hopper Assembly Accupro-2000		16555
	Hopper Assembly SR-2000		16558
2	* Hopper		16554
3	* Helical Cone Assembly		780945
4	* Helical Cone Retainer		791025
	Bearing Shield		23456
5	Helical Cone		780941
6	* Shutoff Plate Retainer		780235
	Shutoff Plate Base		791070
7	* Pointer		790342
8	* Rate Housing Assembly and take off		790321
9	* Rate Control Rod Assembly		790321
	Spring		15460
	Rate Housing		790320-04PS
	Rate control Rod		790390
10	* Rate Control Knob		12704
	Friction washer		12140
11	* Rate Control Plate Accupro-2000		790331
	* Rate Control Plate SR-2000		790331-A
12	* Pivot Lever / Main Shutoff Plate Assembly		790266
13	* Agitator Bearing, Set		792004
14	Agitator Pin		780100
15	Rotor and Gear Carrier Assembly		780195
16	Rotor Shaft		790020
17	Rotor Plate		780191
18	Gear Carrier, complete		780155
19	Pinion Gear		780122
20	Ring Gear		780121
21	Gearbox Cover Half (set of 2)		780110-B
22	Axle Collar (each)		14971-1
	Axle Collar (each)		780200

*Części dostarczane wraz ze zbiornikiem

#Nr.	Nazwa elementu	PL	Nr części
23	Axle, complete		790010
24	Drive Wheel		790120
25	Idler Wheel		790130
26	Axle Bearing (set of 4)		790151
27	Frame Assembly (includes 26) Accupro-2000		790045
	Frame Assembly (includes 26) SR-2000		790046
28	Rest Accupro-2000		790061
	Rest SR-2000		790060
29	Handle Assembly Accupro-2000		790075
	Handle Assembly SR-2000		790076
30	Main Shutoff Lever		790211-04
31	Hand Grips (set of 2)		14870
32	Main Shutoff Control Rod		790250
33	Hopper Screen		790141
34	Hopper Screen Clip (set of 2)		14864
35	Hopper Cover		1067
36	- Auxiliary Shutoff Plate		780220
37	- Auxiliary Shutoff Cable Bracket		790552
38	- Auxiliary Shutoff Control Cable		790490
39	- Auxiliary Shutoff Clamp		790560
40	- Deflector Shield (complete)		1000060
41	- Deflector Lever Bracket		1000059
43	- Deflector Control Rod		1000053
44	- Spring for Deflector Rod		1000052
45	Calibration Key (see calibration instructions)		15740
	Fastener Package (not shown)		790905
200	Parts 36-44: Complete Deflector Kit		1000060

Wszystkie części zamienne i dodatkowe dostarczane są z kompletem zaczepów i instrukcją montażu

IT Far riferimento al diagramma per identificare i singoli pezzi specifici.

 Nel caso di riordino, fornire sempre le seguenti informazioni:
 - indicare SEMPRE il codice del pezzo di ricambio e NON indicare il numero del pezzo
 - fornire la descrizione del pezzo

PL Żeby określić pojedyncze części - skorzystaj ze schematu budowy siewnika.

 Zamawiając części zamienne, zawsze podaj poniższe informacje:
 - ZAWSZE nr części, nie #Nr
 - Nazwę części

Onderdelen bestellen

#Nr.	Beschrijving	NL	Bestelnr.	#Nr.	Beschrijving	NL	Bestelnr.
1	Hopper Assembly Accupro-2000		16555	23	Axle, complete		790010
	Hopper Assembly SR-2000		16558	24	Drive Wheel		790120
2	* Hopper		16554	25	Idler Wheel		790130
3	* Helical Cone Assembly		780945	26	Axle Bearing (set of 4)		790151
4	* Helical Cone Retainer		791025	27	Frame Assembly (includes 26) Accupro-2000		790045
	Bearing Shield		23456		Frame Assembly (includes 26) SR-2000		790046
5	Helical Cone		780941	28	Rest Accupro-2000		790061
6	* Shutoff Plate Retainer		780235		Rest SR-2000		790060
	Shutoff Plate Base		791070	29	Handle Assembly Accupro-2000		790075
7	* Pointer		790342		Handle Assembly SR-2000		790076
8	* Rate Housing Assembly and take off		790321	30	Main Shutoff Lever		790211-04
9	* Rate Control Rod Assembly		790321	31	Hand Grips (set of 2)		14870
	Spring		15460	32	Main Shutoff Control Rod		790250
	Rate Housing		790320-04PS	33	Hopper Screen		790141
	Rate control rod		790390	34	Hopper Screen Clip (set of 2)		14864
10	* Rate Control Knob		12704	35	Hopper Cover		1067
	Friction washer		12140	36	- Auxiliary Shutoff Plate		780220
11	* Rate Control Plate Accupro-2000		790331	37	- Auxiliary Shutoff Cable Bracket		790552
	* Rate Control Plate SR-2000		790331-A	38	- Auxiliary Shutoff Control Cable		790490
12	* Pivot Lever / Main Shutoff Plate Assembly		790266	39	- Auxiliary Shutoff Clamp		790560
13	* Agitator Bearing, Set		792004	40	- Deflector Shield (complete)		1000060
14	Agitator Pin		780100	41	- Deflector Lever Bracket		1000059
15	Rotor and Gear Carrier Assembly		780195	43	- Deflector Control Rod		1000053
16	Rotor Shaft		790020	44	- Spring for Deflector Rod		1000052
17	Rotor Plate		780191	45	Calibration Key (see calibration instructions)		15740
18	Gear Carrier, complete		780155		Fastener Package (not shown)		790905
19	Pinion Gear		780122	200	Parts 36-44: Complete Deflector Kit		1000060
20	Ring Gear		780121				
21	Gearbox Cover Half (set of 2)		780110-B				
22	Axle Collar (each)		14971-1				
	Axle Collar (each)		780200				

*Indicates parts included with hopper assembly

All part and subassembly kits include necessary fasteners and assembly instructions

NL

Raadpleeg het diagram voor het identificeren van de verschillende onderdelen.



Wanneer men een reservestuk bestelt, dan moet dit altijd verzegeld gaan met volgende informatie:

- Gebruik Altijd het bestelnummer, nooit #Nr.
- De beschrijving



Where needs take us



AccuPro 2000



SR-2000